

neo

THE NEXT SENSATION

by Alpha-Bio Tec

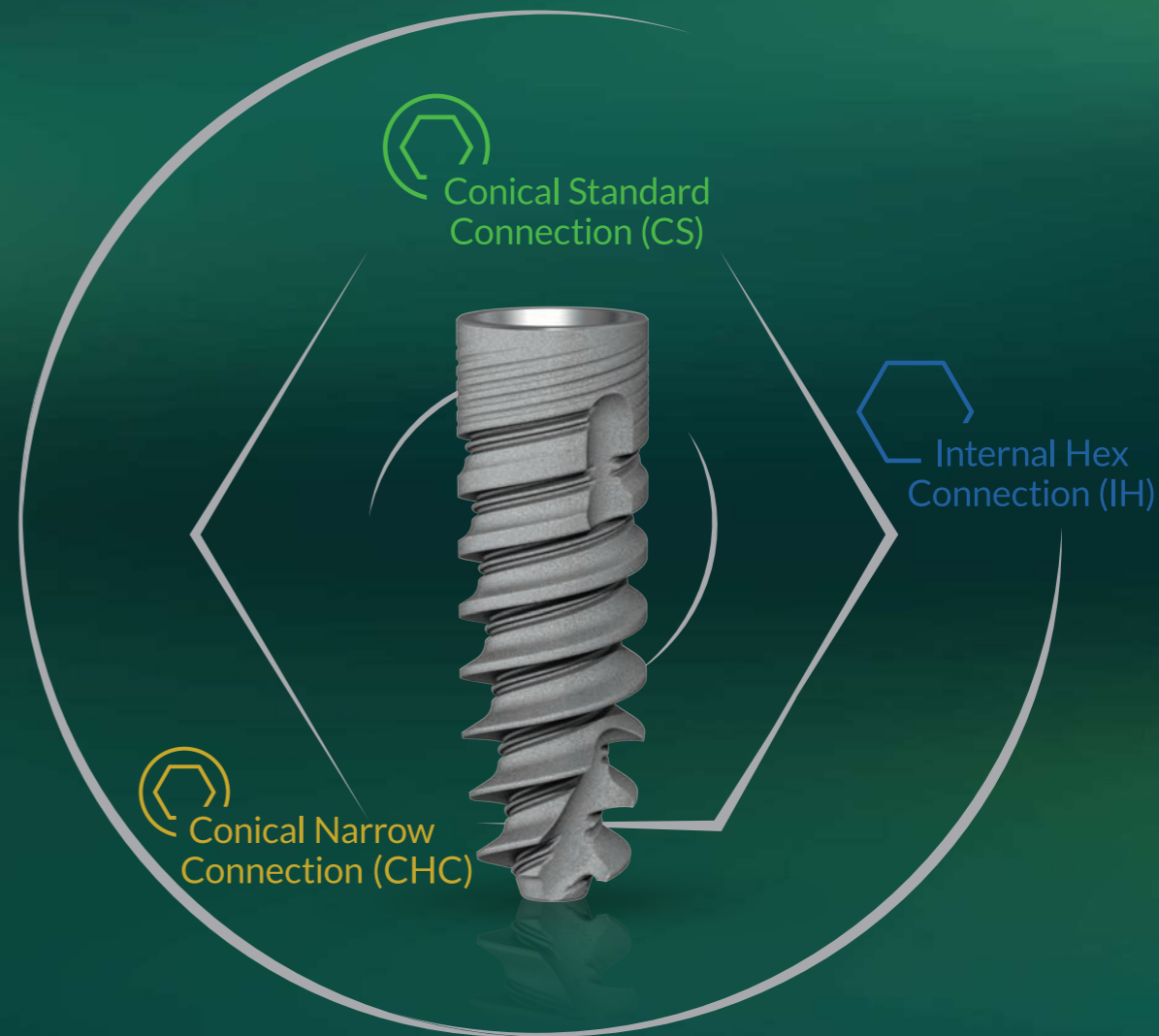

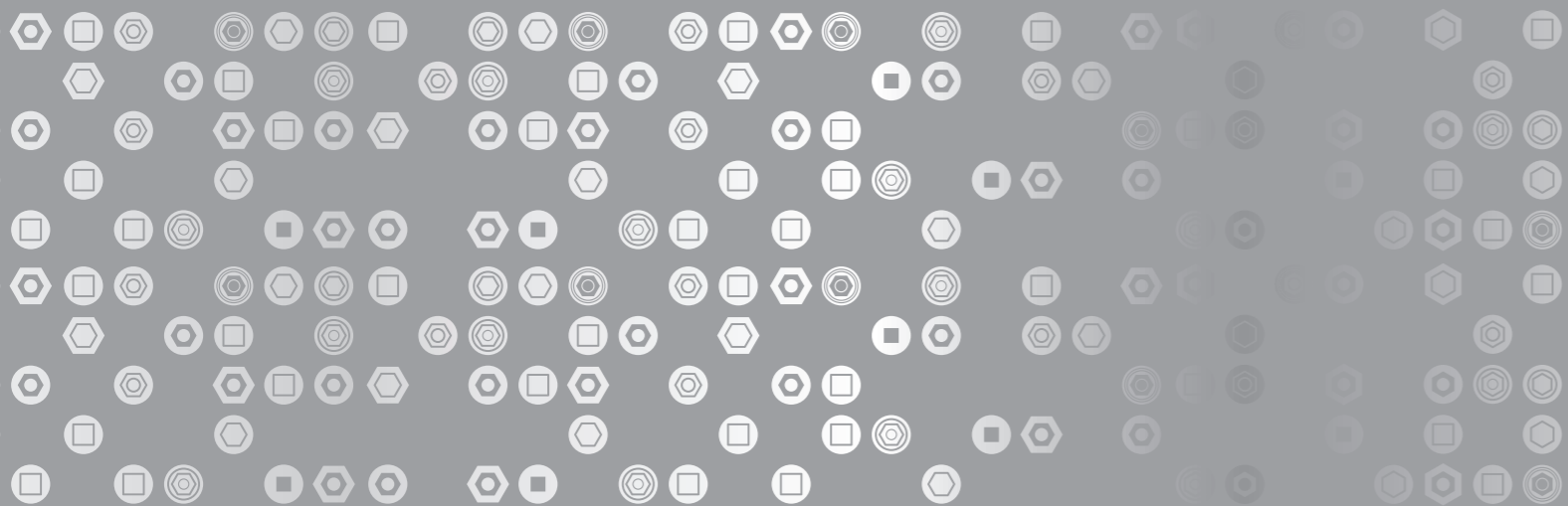

ONE **neO**

MULTIPLE OPTIONS

Alpha-Bio Tec is proud to present the next sensation of dental solutions - the NeO implant system.

NeO is the next generation of the Alpha-Bio Tec's original spiral implant. It is based on three decades of proven clinical know-how and rooted in the company's values of high-quality, innovation, best value for money and simplicity.

NeO is a comprehensive, cutting-edge implant that easily penetrates and navigates the osteotomy of all bone types while preserving the bone. It simplifies even the most complicated clinical cases reliability and long-term esthetic results.

The new NeO system includes three connections: Conical Standard connection (CS), Conical Narrow connection (CHC) and Internal Hex connection (IH), providing dental professionals with a variety of options to choose from.

The NeO Conical Standard connection (CS) features a dedicated restoration line with a unique design. All parts correspond with each other in complete harmony, enabling improved functionality, esthetics and a perfect biological fit.

Experience NeO to fully understand how brilliant it is!

Design Features and Benefits

Years of experience in product development and state-of-the-art technology enables Alpha-Bio Tec to deliver high-quality implants with unique design features that achieved the following clinical advantages:

ONE IMPLANT MULTIPLE OPTIONS



Conical Narrow Connection (CHC)
Ø 3.2, Ø 3.5



Conical Standard Connection (CS)
Ø 3.75, Ø 4.2, Ø 5.0

New Launch!



Internal Hex Connection (IH)
Ø 3.75, Ø 4.2, Ø 5.0



CORONAL AREA

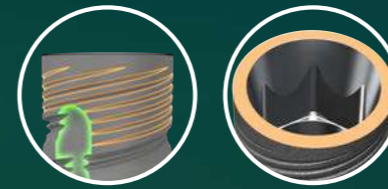

Design Features

- Platform switching
- Micro threads
- Cutting flutes
- IH and conical connections (CS & CHC)

Clinical Advantages / Benefits

- Reduced pressure on cortical part
- Gentle, delicate cutting
- Improved bone preservation
- High initial stability
- Long-term and stable esthetic results

THREADS

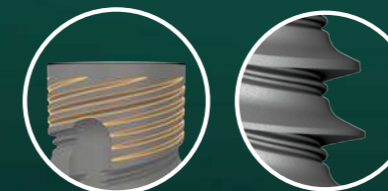

Design Features

- Unique threads shape
- Double threads with 2.4 mm step
- Two micro threads
- Variable threads design

Clinical Advantages / Benefits

- High cutting efficiency
- Optimal bone condensing
- Fast insertion
- Excellent bone grip
- Greater surface area (BIC), increasing profile surface by 20%

BODY AND CORE

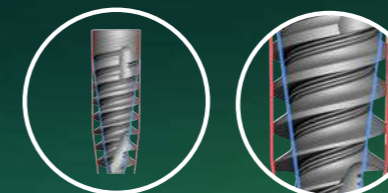

Design Features

- Implant outer line:
- Straight coronal part
 - Slightly tapered body
 - Tapered apical part
 - Tapered core

Clinical Advantages / Benefits

- Optimal bone condensing
- High primary stability
- Reduced pressure along implant's body

APICAL AREA

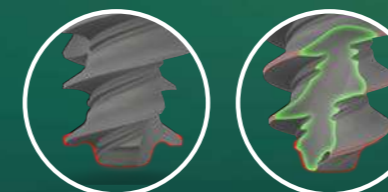

Design Features

- Narrow apex
- Sharp and deep threads
- Condensing flutes
- Centering feature and gripping tips

Clinical Advantages / Benefits

- High & firm primary engagement
- Easy navigation and penetration
- High cutting efficiency

PATENTED

Scientific Data

Special attention has been taken in evaluating all sections of the implant: coronal, body and apical, to ensure consistent & outstanding clinical results for the implant profile.

Histological Studies

Score of Bone to Implant Contact is up to 94%

Histologic evaluation showed significant osseointegration with healthy young woven bone, 1 month after implantation.

The average BIC value was 87.24%, while the maximum value was 94%.

The perfectly demonstrated osseointegration is the result of the unique design of the NeO implant profile and the high surface purity.

Coronal Area
(Magnification x 10)

Overgrowth of the bone above the implant shoulder (white circle).

Coronal Flute Area
(Magnification x 10)

Woven bone is detected at the coronal flute area showing osseointegration, demonstrating an attractive implant surface which encourages good growth during wound healing of the prepared osteotomies.

Implant Micro and Macro Threads
(Magnification x 100)

There is a perfect adhering between the new bone and the implant surface, creating a close adaptation to the macro and micro-design of NeO implant body. This adaptation is also possible due to the perfect clean surface of the implant.
Microthread increases the implant contact surface by 20%.

Apical Area
(Magnification x 100)

A tapered narrow apical section with deep and sharp threads enables ideal retention in soft and spongy bone.

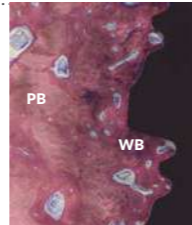
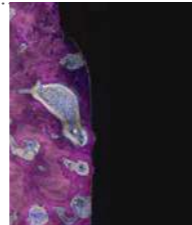

★ Implant cervical micro threads **WB:** Zone of young woven bone filling the micro-gap between implant and osteotomy **PB:** Pristine bone

NeO's Surface NANOTECH™

NanoTec™ is a hybrid implant surface formed through a complex process that involves large particles (20-40 microns) sandblasting and a double thermal etching to create micro & nano pores (sized 1-5 microns). This unique process produces a high surface area differentiation, increases the three-dimensional (3D) surface area and thereby, enables a more intense absorption of blood and plasma proteins directly into the implant's micropores, immediately after the implant is placed. State-of-the-art surface treatment technologies at the Alpha-Bio Tec manufacturing facility ensure unified surface treatment application and precision.

NanoTec™ implant surface process advantages:

- Increased early BIC (Bone to Implant Contact)
- High and long-term BIC
- Accelerated and improved osseointegration process
- Increased secondary stability
- Shortened healing period
- High success rate

SEM of NeO implant surface

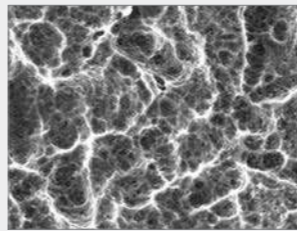

Surface morphology of the implant
(Magnification by 3000)

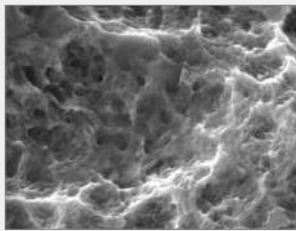

Surface morphology of the implant
(Magnification by 12000)

NeO's Clinical Indications

Clinical studies have shown the advantages of using NeO in the majority of clinical procedures, and especially in complicated clinical cases such as:

- Extreme bone defects
- Full and partial immediate implantation and immediate loading
- Implantation and simultaneous guided bone regeneration and/or splitting crest whnique
- Extreme narrow alveolar ridges (< 4mm)
- Closed and open sinus lift procedures

NeO's scientific overview, pre-clinical study, implant surface purity and performance - treatment concepts and indications - are all presented in NeO's comprehensive Clinical Book.



Scan to View Clinical Book

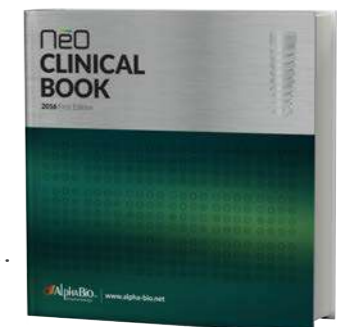

Balanced to Perfection

With innovative stress reduction elements designed together with primary stability enhancers, NeO is truly balanced to perfection. Powerful, yet remarkably gentle to all bone types.

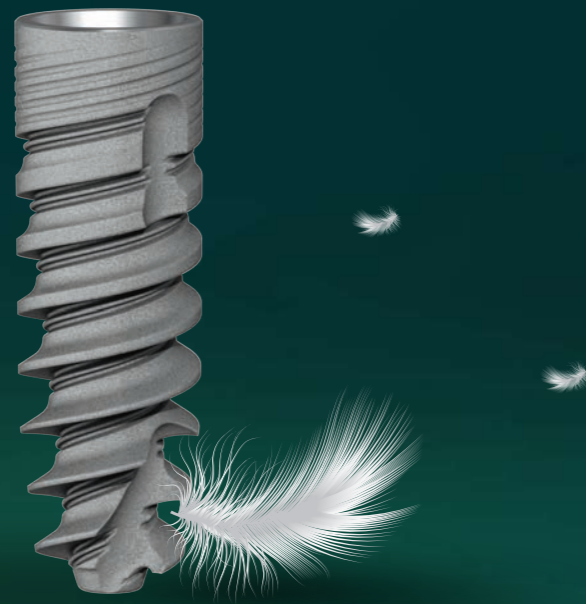

Gentle to the Bone

The **platform switching** has proved to preserve the cortical bone around the implant neck by physically repositioning the implant-abutment connection away from the bone level.

The coronal **micro threads** decrease the load transfer to the crestal cortical bone, resulting in significant bone preservation.

The concave geometry of the coronal **cutting flute** minimizes the pressure applied on the cortical bone.

The implant's advanced **threads shape** with sharp "attack angle" contributes to fast and smooth insertion, and minimizes lateral stress after insertion.

Body micro threads' geometry disperses the forces applied on the bone, thereby decreasing the bone pressure.



High Primary Stability

The **straight design of the coronal part of NeO** produces greater contact surface between the bone and the implant coronal part, thereby providing better initial stability.

The osteotome - like **tapered core** of the implant combined with the slightly tapered implant **body** generate optimal bone condensing ability.

The **large pitch and variable threads** create optimal bone condensation, while the two body micro-threads increase BIC.

The narrow tapered **apical part** of the implant penetrates easily to small diameter osteotomy. Its sharp and deep threads, together with the **gripping tips**, were developed to produce firm primary engagement as well as an increased primary stability.

Advanced System

The NeO system includes narrow & standard implant lines with a choice of implant-abutment connection platforms. It comes in a mountless package and with advanced grip drivers.



Implant Package

A modern and easy-to-use package, designed for maximum comfort and enhanced ergonomics.



Identification Labels

Label indicates the implant type, length, diameter and connection (CHC / CS / IH).



Color-coded Holder

Holders are color-coded for easy identification of implant length.



PATENT PENDING

Stack Several Packages Together

The unique design enables the stacking of several packages together for maximum storage space efficiency.

Implant Grip Drivers

New, advanced and modern grip drivers for maximum confidence. Each set of drivers is compatible with the appropriate platform: Conical Narrow (CHC), Conical Standard (CS) and Internal Hex (IH), differentiated by the following color coding: **Gold=CHC** **Green=CS** **Blue=IH**

The grip feature in the new design allows direct and secure implant pick-up from package to site feature. Drivers are available in three different forms and in various lengths for physician's best practice.

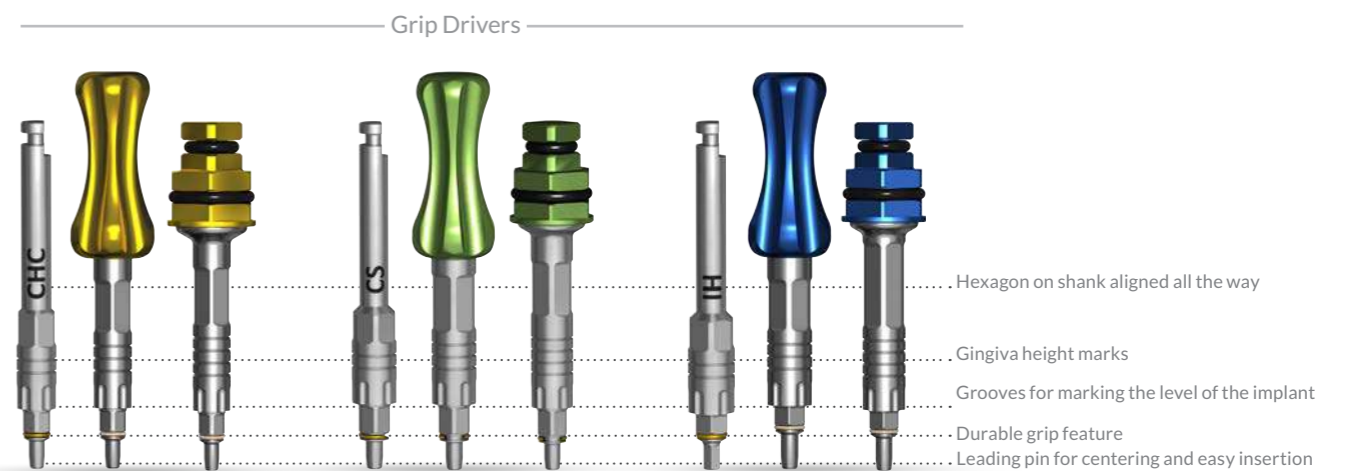

1

Tear the cardboard.

2

Pull the Tyvek.

3

Remove the inner holder.

4

Open the cap - easy one-hand operation.



5

Insert the preferred driver in a continuous clockwise turn until hex is found. (Wrench is for illustration only)

6

Implant is now connected to the driver and can be removed. Verify there is no gap between the driver and the implant.

7

Implant can be inserted directly to site.

8

Remove cover screw using an appropriate prosthetic driver.

Drill Protocol

Two Ways, One Result

Step Drilling Sequence

Ø Diameter	Soft bone Type IV	Medium bone Type II&III	Hard bone Type I
Ø 3.2	2.0	2.0 2.4/2.8	2.0 2.4/2.8 2.8/3.0
Ø 3.5	2.0 2.0/2.4	2.0 2.4/2.8 2.8/3.0	2.0 2.4/2.8 2.8/3.2
Ø 3.75	2.0 2.4/2.8	2.0 2.4/2.8 2.8/3.2	2.0 2.4/2.8 2.8/3.2 3.2/3.65 Cortical
Ø 4.2	2.0 2.4/2.8 2.8/3.2	2.0 2.4/2.8 3.2/3.65	2.0 2.4/2.8 3.2/3.65 3.65/4.1 Cortical
Ø 5.0	2.0 2.4/2.8 3.2/3.65	2.0 2.4/2.8 3.2/3.65 3.65/4.1	2.0 2.4/2.8 3.2/3.65 3.65/4.1 4.1/4.5 4.5/4.8 Cortical

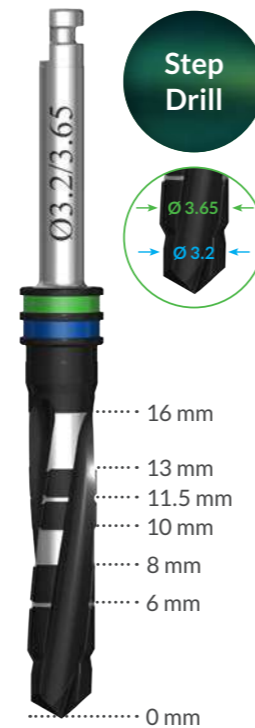

Cortical – Drill through cortical plate with the larger diameter

Demonstration of NeO recommended drill protocol with Ø 3.75/13 mm implant using step drills, bone type II/III

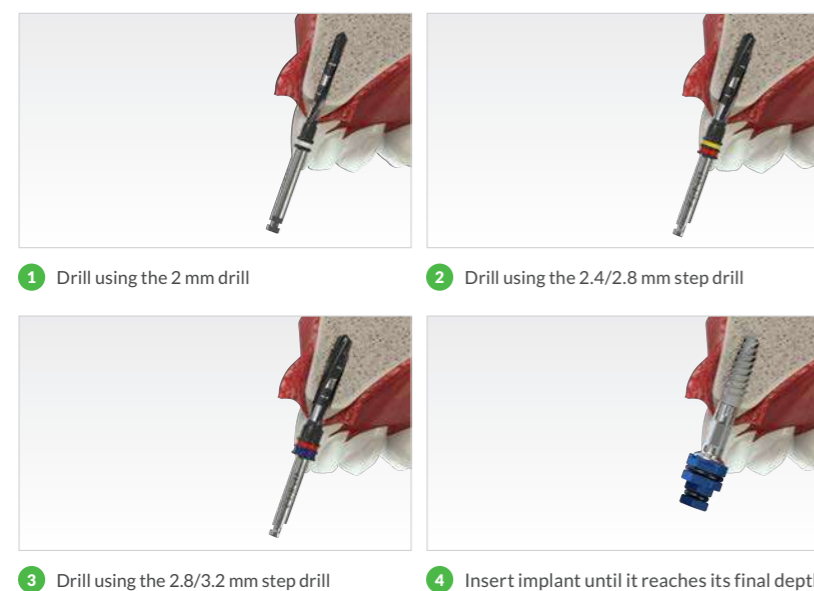

- 1 Drill using the 2 mm drill
- 2 Drill using the 2.4/2.8 mm step drill
- 3 Drill using the 2.8/3.2 mm step drill
- 4 Insert implant until it reaches its final depth

Straight Drilling Sequence

Ø Diameter	Soft bone Type IV	Medium bone Type II&III	Hard bone Type I
Ø 3.2	2.0	2.0 2.4/2.8	2.0 2.8 2.8/3.0
Ø 3.5	2.0 2.0/2.4	2.0 2.8 2.8/3.0	2.0 2.8 2.8/3.2
Ø 3.75	2.0 2.4/2.8	2.0 2.8 2.8/3.2	2.0 2.8 2.8/3.2 3.65 Cortical
Ø 4.2	2.0 2.8 2.8/3.2	2.0 2.8 3.2 3.2/3.65	2.0 2.8 3.2 3.2/3.65 4.1 Cortical
Ø 5.0	2.0 2.8 3.2 3.2/3.65	2.0 2.8 3.2 3.65 3.65/4.1	2.0 2.8 3.2 3.65 4.1 4.1/4.5 4.8 Cortical

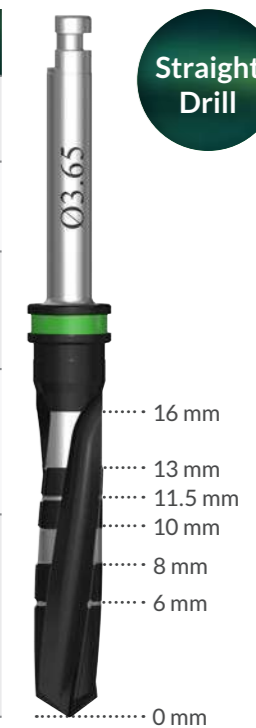

Cortical – Drill through cortical plate
Step drill can be replaced with straight drill by drilling 3 mm less

Demonstration of NeO recommended drill protocol with Ø 3.75/13 mm implant using straight drills, bone type II/III

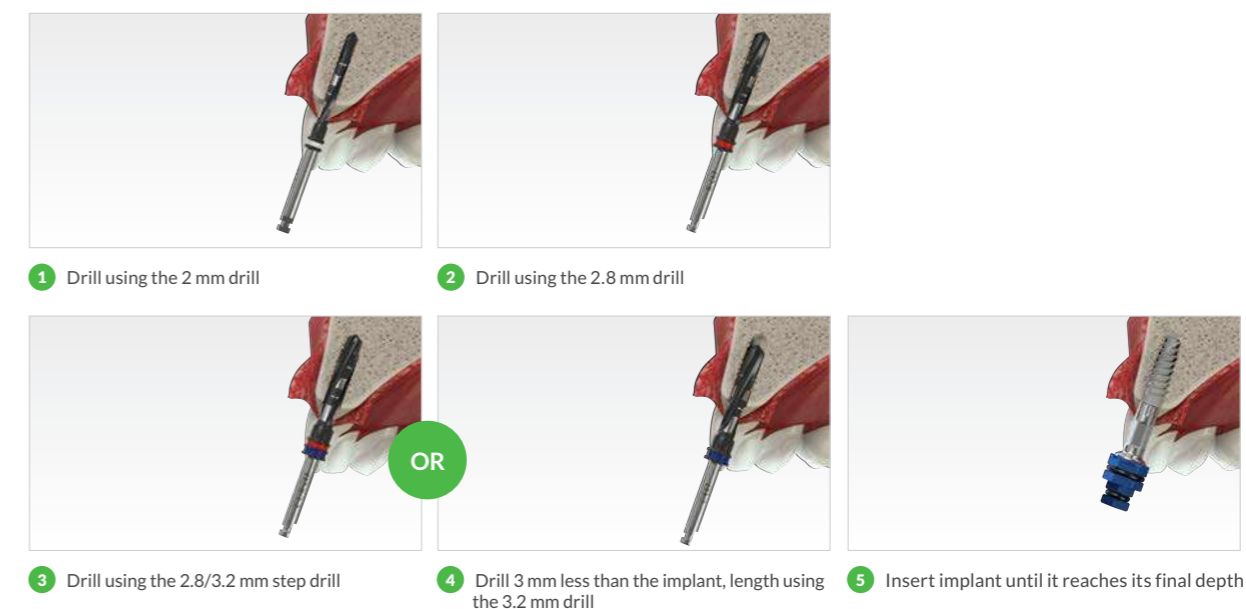

- 1 Drill using the 2 mm drill
- 2 Drill using the 2.8 mm drill
- 3 Drill using the 2.8/3.2 mm step drill
- 4 Drill 3 mm less than the implant, length using the 3.2 mm drill
- 5 Insert implant until it reaches its final depth

Ordering Information

Experience NeO to fully understand how brilliant it is.

Conical Narrow Connection (CHC)

The conical narrow connection system includes \varnothing 3.2 and \varnothing 3.5 mm implant diameters with conical narrow connection for narrow space procedures, compatible with Alpha-Bio's CHC prosthetic line and CAD/CAM restoration parts.

Diameter	Length	Ref. No.	Dimensions				
			A	B	C	D	H
\varnothing 3.2	8 mm	1108	\varnothing 3.2	\varnothing 2.9	\varnothing 1.5	\varnothing 2.5	2.1
	10 mm	1100	\varnothing 3.2	\varnothing 2.9	\varnothing 1.5	\varnothing 2.5	2.1
	11.5 mm	1101	\varnothing 3.2	\varnothing 2.9	\varnothing 1.5	\varnothing 2.5	2.1
	13 mm	1103	\varnothing 3.2	\varnothing 2.9	\varnothing 1.5	\varnothing 2.5	2.1
	16 mm	1106	\varnothing 3.2	\varnothing 2.9	\varnothing 1.5	\varnothing 2.5	2.1
\varnothing 3.5	8 mm	1128	\varnothing 3.5	\varnothing 2.9	\varnothing 1.5	\varnothing 2.5	2.1
	10 mm	1120	\varnothing 3.5	\varnothing 2.9	\varnothing 1.5	\varnothing 2.5	2.1
	11.5 mm	1121	\varnothing 3.5	\varnothing 2.9	\varnothing 1.5	\varnothing 2.5	2.1
	13 mm	1123	\varnothing 3.5	\varnothing 2.9	\varnothing 1.5	\varnothing 2.5	2.1
	16 mm	1126	\varnothing 3.5	\varnothing 2.9	\varnothing 1.5	\varnothing 2.5	2.1

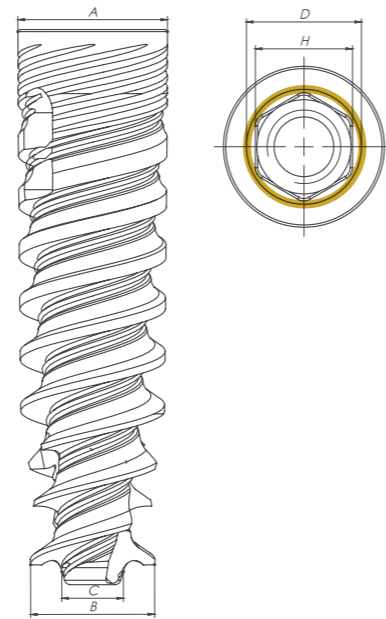

Conical Standard Connection (CS)

The conical standard connection includes \varnothing 3.75, \varnothing 4.2 and \varnothing 5.0 mm implant diameters. The implants are compatible with the new CS prosthetic line and the CAD/CAM restoration parts (see pages 18-23).

Diameter	Length	Ref. No.	Dimensions				
			A	B	C	D	H
\varnothing 3.75	8 mm	1138	\varnothing 3.75	\varnothing 3.1	\varnothing 1.8	\varnothing 3.1	2.5
	10 mm	1130	\varnothing 3.75	\varnothing 2.9	\varnothing 1.5	\varnothing 3.1	2.5
	11.5 mm	1131	\varnothing 3.75	\varnothing 2.9	\varnothing 1.5	\varnothing 3.1	2.5
	13 mm	1133	\varnothing 3.75	\varnothing 2.9	\varnothing 1.5	\varnothing 3.1	2.5
	16 mm	1136	\varnothing 3.75	\varnothing 2.9	\varnothing 1.5	\varnothing 3.1	2.5
\varnothing 4.2	8 mm	1148	\varnothing 4.2	\varnothing 3.55	\varnothing 1.8	\varnothing 3.1	2.5
	10 mm	1140	\varnothing 4.2	\varnothing 3.3	\varnothing 1.8	\varnothing 3.1	2.5
	11.5 mm	1141	\varnothing 4.2	\varnothing 3.3	\varnothing 1.8	\varnothing 3.1	2.5
	13 mm	1143	\varnothing 4.2	\varnothing 3.3	\varnothing 1.8	\varnothing 3.1	2.5
	16 mm	1146	\varnothing 4.2	\varnothing 3.3	\varnothing 1.8	\varnothing 3.1	2.5
\varnothing 5.0	8 mm	1158	\varnothing 5.0	\varnothing 4.4	\varnothing 2.6	\varnothing 3.1	2.5
	10 mm	1150	\varnothing 5.0	\varnothing 4.1	\varnothing 2.3	\varnothing 3.1	2.5
	11.5 mm	1151	\varnothing 5.0	\varnothing 4.1	\varnothing 2.3	\varnothing 3.1	2.5
	13 mm	1153	\varnothing 5.0	\varnothing 4.1	\varnothing 2.3	\varnothing 3.1	2.5

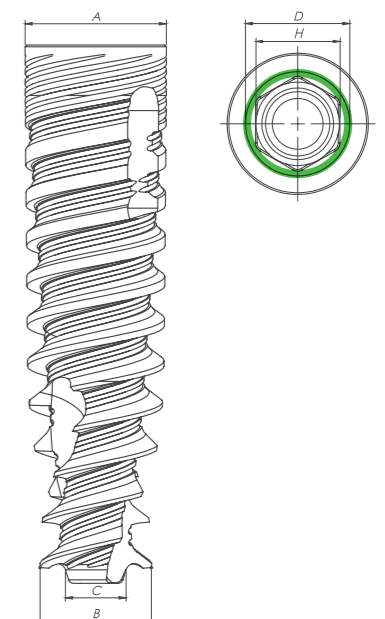

Manual	Motor Mount	Wrench
<p>MITD 2.1 CHC 4147</p>	<p>IT 2.1 LM CHC 7303</p> <p>IT 2.1 SM CHC 7304</p>	<p>ITD 2.1 L CHC 7301</p> <p>ITD 2.1 CHC 7305</p> <p>ITD 1.25 S CHC 7302</p>

Manual	Motor Mount	Wrench
<p>MITD 2.5 CS 3806</p>	<p>IT 2.5 LM CS 3805</p> <p>IT 2.5 SM CS 3804</p>	<p>ITD 2.5 L CS 3803</p> <p>ITD 2.5 S CS 3801</p>

Ordering Information

Experience NeO to fully understand how brilliant it is.

Internal Hex Connection (IH)

The internal hex connection includes \varnothing 3.75, \varnothing 4.2 and \varnothing 5.0 implant diameters, compatible with Alpha-Bio's IH prosthetic line and CAD/CAM restoration parts.

Diameter	Length	Ref. No.	Dimensions				
			A	B	C	D	H
\varnothing 3.75	8 mm	1168	\varnothing 3.75	\varnothing 3.1	\varnothing 1.8	\varnothing 3.5	2.5
	10 mm	1160	\varnothing 3.75	\varnothing 2.9	\varnothing 1.5	\varnothing 3.5	2.5
	11.5 mm	1161	\varnothing 3.75	\varnothing 2.9	\varnothing 1.5	\varnothing 3.5	2.5
	13 mm	1163	\varnothing 3.75	\varnothing 2.9	\varnothing 1.5	\varnothing 3.5	2.5
\varnothing 4.2	8 mm	1178	\varnothing 4.2	\varnothing 3.55	\varnothing 1.8	\varnothing 3.5	2.5
	10 mm	1170	\varnothing 4.2	\varnothing 3.3	\varnothing 1.8	\varnothing 3.5	2.5
	11.5 mm	1171	\varnothing 4.2	\varnothing 3.3	\varnothing 1.8	\varnothing 3.5	2.5
	13 mm	1173	\varnothing 4.2	\varnothing 3.3	\varnothing 1.8	\varnothing 3.5	2.5
\varnothing 5.0	8 mm	1188	\varnothing 5.0	\varnothing 4.4	\varnothing 2.6	\varnothing 3.5	2.5
	10 mm	1180	\varnothing 5.0	\varnothing 4.1	\varnothing 2.3	\varnothing 3.5	2.5
	11.5 mm	1181	\varnothing 5.0	\varnothing 4.1	\varnothing 2.3	\varnothing 3.5	2.5
	13 mm	1183	\varnothing 5.0	\varnothing 4.1	\varnothing 2.3	\varnothing 3.5	2.5

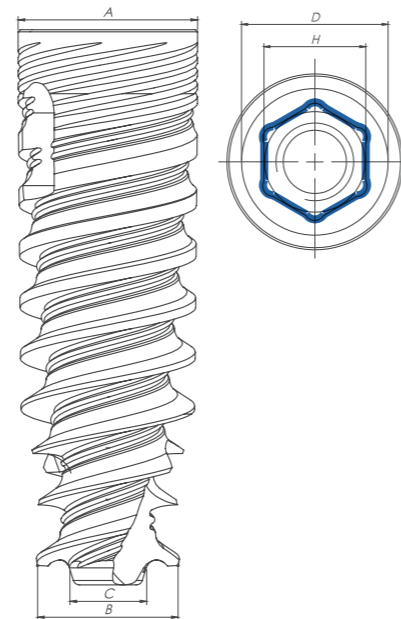

ONE SURGICAL KIT for all implant systems



- A new tray design and layout – fits all tools and drills required for any of Alpha-Bio Tec's implant systems.
- Ergonomic, compact and easy to carry.
- Shock-resistant silicon holders enabling stable movement during transit.
- Clear, color-coded visual design, for easy and intuitive accessibility.
- Laser etched marking on tray, including a dimension bar for effective drill depth verification.
- Easy cleaning and autoclaveable, guaranteeing 1000 sterilization cycles.

* Kit is provided empty. Tools and drills must be ordered separately.

Manual	Motor Mount	Wrench
<p>MITD 2.5 IH 4146</p>	<p>GITL 1.25 LM IH 4143</p> <p>GITS 1.25 S M IH 4145</p>	<p>GITD 2.5 L IH 4140</p> <p>GITD 2.5 M IH 4141</p> <p>GITD 2.5 S IH 4142</p>

**New
Launch!**

Conical Standard CS Restoration Line

The philosophy behind the prosthetic line focuses on soft tissue for enhanced, long-term esthetics through biological design. All products in the line – from healing abutments to through impression to the final restoration - harmoniously correspond with each other. This approach delivers functionality, esthetics and minimal maintenance.

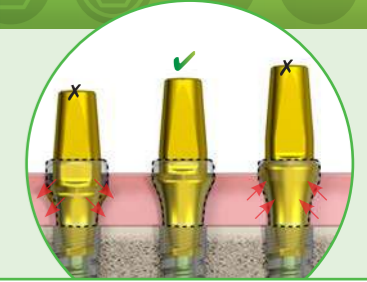

Choosing the correct abutment cuff height

The concavity of the abutment's gingival area design corresponds with the healing abutment's design of the same height. Use of improper abutment cuff height may result in a misfit gingival align.

- All prosthetic parts match in their design, thus enhancing the long-term stability of the soft tissue for better esthetic results
- Various heights and width options are available for different gingival indications
- CS products are color-coded in green for pre-and post-surgery identification
- Advanced design supports platform switching

Healing Abutments

- Concaved design promoting better soft tissue healing for long-term esthetical results*
- Five healing abutments for different cuff heights
- Laser marking for easy diameter and height identification
- Perfect match with abutment cuff height design



Choosing the correct healing abutment

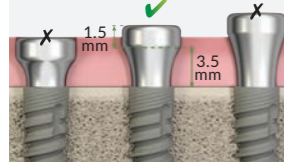

The healing abutment should be chosen according to the given gingival height. The healing abutment concaved area varies from 1.5 to 5.5 mm, with a constant straight top of 1.5 mm suitable for most clinical situations. The healing abutment should protrude from the soft tissue margin, as shown.

Broadening of the soft tissue

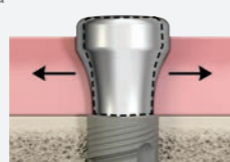

If broadening of the soft tissue is required, it is possible to use a slim healing abutment (Ø 4.0 mm) first, and then switch to a standard or wide healing abutment (Ø 4.9 or Ø 6.2 mm), according to the clinical requirements.

* Use 1.25 mm driver.

Healing Abutments Ø 4.0 mm

Dimensions	A: Ø 4.0 mm B: 1.5 mm C: 3 mm	A: Ø 4.0 mm B: 2.5 mm C: 4 mm	A: Ø 4.0 mm B: 3.5 mm C: 5 mm	A: Ø 4.0 mm B: 4.5 mm C: 6 mm	A: Ø 4.0 mm B: 5.5 mm C: 7 mm
Code	HA-D-4-CH-1.5-CS	HA-D-4-CH-2.5-CS	HA-D-4-CH-3.5-CS	HA-D-4-CH-4.5-CS	HA-D-4-CH-5.5-CS
Ref. No.	3401	3402	3403	3404	3405

Healing Abutments Ø 4.9 mm

Dimensions	A: Ø 4.9 mm B: 1.5 mm C: 3 mm	A: Ø 4.9 mm B: 2.5 mm C: 4 mm	A: Ø 4.9 mm B: 3.5 mm C: 5 mm	A: Ø 4.9 mm B: 4.5 mm C: 6 mm	A: Ø 4.9 mm B: 5.5 mm C: 7 mm
Code	HA-D-4.9-CH-1.5-CS	HA-D-4.9-CH-2.5-CS	HA-D-4.9-CH-3.5-CS	HA-D-4.9-CH-4.5-CS	HA-D-4.9-CH-5.5-CS
Ref. No.	3407	3408	3409	3410	3411

Healing Abutments Ø 6.2 mm

Dimensions	A: Ø 6.2 mm B: 1.5 mm C: 3 mm	A: Ø 6.2 mm B: 2.5 mm C: 4 mm
Code	HA-D-6.2-CH-1.5-CS	HA-D-6.2-CH-2.5-CS
Ref. No.	3412	3413

Impression

- Allows closed/open tray techniques as well as plastic snap-on
- Advanced supra gingival design for enhanced impression accuracy
- Matching of the trans-gingival design minimizes soft tissue collapse

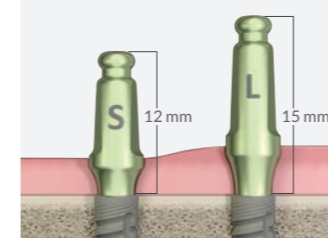

Transfer selection

It is recommended to use the short or long closed/open tray transfers with the utmost fit to the gingival design and the adjacent structures.





Short Closed Tray Transfer Long Closed Tray Transfer Short Open Tray Transfer Long Open Tray Transfer Plastic Transfer - PickUp Analog



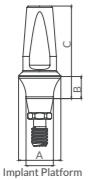

Code	SCTT-CS	LCTT-CS	RCTT-CS	RCTTS-CS	HTLASP	IA-CS
Ref. No.	3450	3451	3455	3456	5364	3459

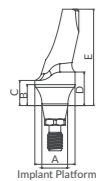

**New
Launch!**

Conical Standard CS Restoration Line

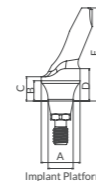
Cement-retained Restoration

Straight Titanium Abutments				
				
Dimensions	A: Ø 4.8 mm B: 1.5 mm C: 9.5 mm	A: Ø 4.8 mm B: 2.5 mm C: 10.5 mm	A: Ø 4.8 mm B: 3.5 mm C: 11.5 mm	A: Ø 4.8 mm B: 4.5 mm C: 12.5 mm
Code	TLA-H-1.5-CS	TLA-H-2.5-CS	TLA-H-3.5-CS	TLA-H-4.5-CS
Ref. No.	3501	3502	3503	3504

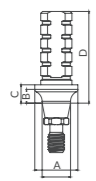

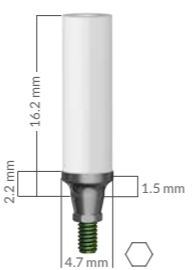
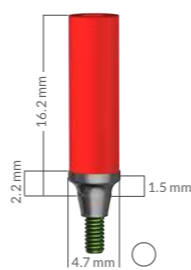



15° Angled Titanium Abutments		25° Angled Titanium Abutments			
					
Dimensions	A: Ø 4.8 mm B: 1.5 mm C: 2 mm D: 3 mm E: 10.5 mm	A: Ø 4.8 mm B: 2.5 mm C: 3 mm D: 4 mm E: 11.5 mm	Dimensions	A: Ø 4.8 mm B: 1.5 mm C: 2 mm D: 3 mm E: 10.5 mm	A: Ø 4.8 mm B: 2.5 mm C: 2 mm D: 3 mm E: 11.5 mm
Code	TLA-15-H-1.5-CS	TLA-15-H-2.5-CS	Code	TLA-25-H-1.5-CS	TLA-25-H-2.5-CS
Ref. No.	3511	3512	Ref. No.	3514	3515

Temporary Titanium Abutments		Casting Abutments			
					
Dimensions	A: Ø 4.7 mm B: 1.5 mm C: 2 mm D: 10 mm	A: Ø 4.7 mm B: 1.5 mm C: 2 mm D: 10 mm	Dimensions	A: Ø 4.7 mm B: 1.5 mm C: 2 mm D: 10 mm	
Code	TA-AR-CS	TA-R-CS	Code	CoCr-AR-CHCS	CoCr-R-CHCS
Ref. No.	3532	3533	Ref. No.	3846	3847

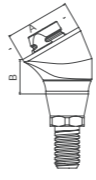



Screw-retained Restoration

Multiple Implants Restoration: Alpha Universe Multi-Unit Abutment System

Angled abutments for aligning the prosthetic platform when using tilted implants

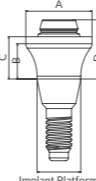



17° Angled Abutments			30° Angled Abutments			
						
Dimensions	A: Ø 4.7 mm B: 1.5 mm	A: Ø 4.7 mm B: 2.5 mm	A: Ø 4.7 mm B: 3.5 mm	A: Ø 4.7 mm B: 1.5 mm	A: Ø 4.7 mm B: 2.5 mm	A: Ø 4.7 mm B: 3.5 mm
Code	AU-17-1.5-CS	AU-17-2.5-CS	AU-17-3.5-CS	AU-30-1.5-CS	AU-30-2.5-CS	AU-30-3.5-CS
Ref. No.	3862	3863	3864	3867	3868	3869

* Use 1.25 mm driver @30Ncm.

Straight Abutments For restoration of up to 30° diversion between implants			
			
Dimensions	A: Ø 4.7 mm B: 0.5 mm C: 0.75 mm D: 1.9 mm	A: Ø 4.7 mm B: 1.5 mm C: 2 mm D: 3.2 mm	A: Ø 4.7 mm B: 2.5 mm C: 3 mm D: 4.2 mm
Code	TCT-0.75-CS	TCT-1.5-CS	TCT-2.5-CS
Ref. No.	3870	3871	3872

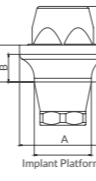
Supra structure on top of the abutments remains the same and can be used with Alpha Universe products. Use 1.5 mm driver @30Ncm.

Single Implant Restoration

Straight Abutments				
				
Dimensions	A: Ø 4.7 mm B: 0.5 mm C: 0.75 mm D: 2.8 mm	A: Ø 4.7 mm B: 1.5 mm C: 2 mm D: 4.1 mm	A: Ø 4.7 mm B: 2.5 mm C: 3 mm D: 5.1 mm	Note: Abutments are supplied with a screw and a plastic burnout sleeve.
Code	HBC-H-0.75-CS	HBC-H-1.5-CS	HBC-H-2.5-CS	
Ref. No.	3876	3877	3878	





* Use 1.25 mm driver @30Ncm.

**New
Launch!**

Conical Standard CS Restoration Line

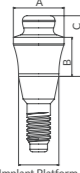
Overdenture Restoration





AlphaLoc Straight Abutments

				
Dimensions	A: Ø 3.1 mm B: 0.75 mm C: 2.4 mm	A: Ø 3.9 mm B: 2 mm C: 3.7 mm	A: Ø 3.9 mm B: 3 mm C: 4.7 mm	A: Ø 3.9 mm B: 4 mm C: 5.7 mm
Code	AA-0.75 - CS	AA-1.5 - CS	AA-2.5 - CS	AA-3.5 - CS
Ref. No.	3710	3711	3712	3713

Abutments are supplied in a kit including: 1 attachment of the given height, 1 stainless steel metal housing, 4 retentive caps, 1 protective disc and 1 laboratory cap (refer to page 56 in the catalog).

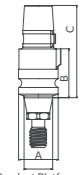
* Use 1.25 mm driver @30Ncm.

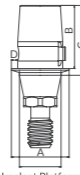
Sirona Compatible

Sirona Scan Post		Sirona Ti Base	
			
Dimensions	A: Ø 4.3 mm B: 5.3 mm C: 10 mm	Dimensions	A: Ø 4.3 mm B: 4.7 mm C: 5.2 mm D: 0.48 mm
Code	CSSP-CS-SI	Code	CSTB-CS-SI
Ref. No.	3857	Ref. No.	3856

* Use 1.25 mm driver @30Ncm.

For IH and CHC prosthetic parts, refer to our catalog:





ONE **neO** MULTIPLE OPTIONS



The Complete **neO** Implant Family

With more options to choose from, the NeO family now includes 3 connections:

 **Conical Narrow Connection (CHC)**

 **Conical Standard Connection (CS)**

 **Internal Hex Connection (IH)**

Each connection features a dedicated restoration line

AlphaBio^{TEC}
Simplantology

neo

THE NEXT SENSATION

by Alpha-Bio Tec

 AlphaBio^{TEC}
Implantology

